

TANK DIMENSIONS

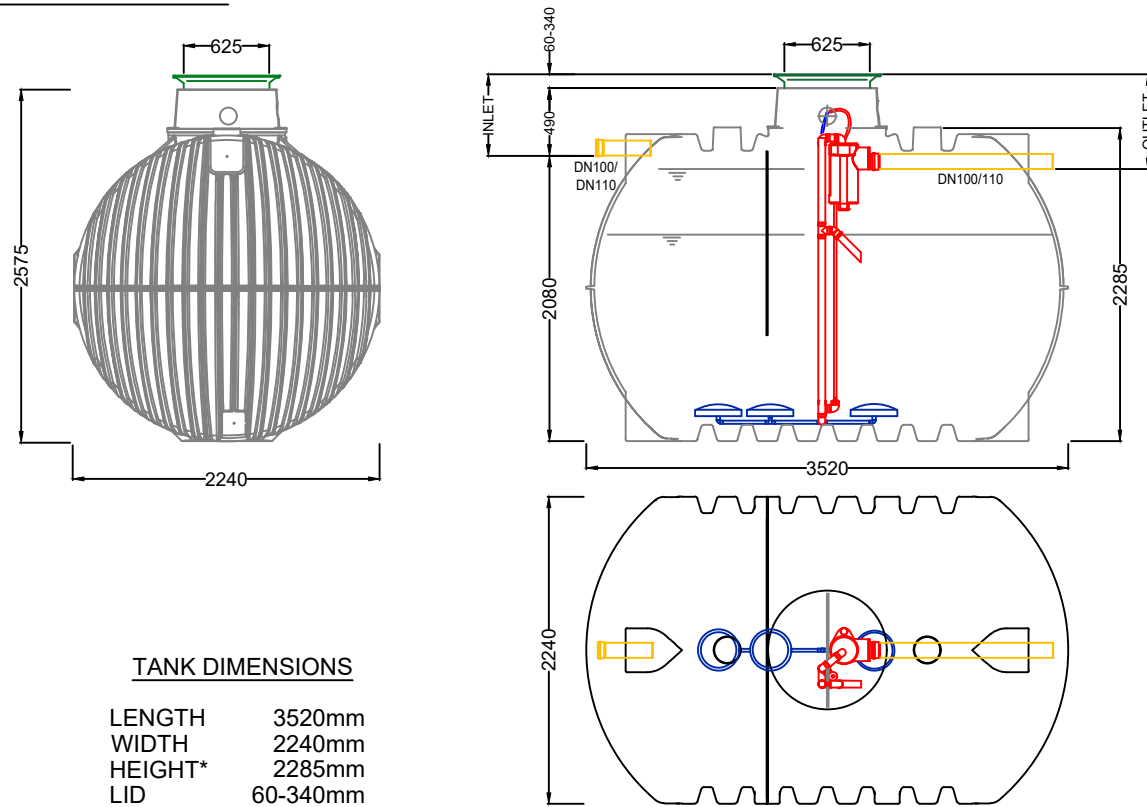

TANK DIMENSIONS

LENGTH	3520mm
WIDTH	2240mm
HEIGHT*	2285mm
LID	60-340mm
INLET	490mm + Lid
OUTLET	590mm + Lid

*WITHOUT DOME OR LID

PIPE SCHEMATIC

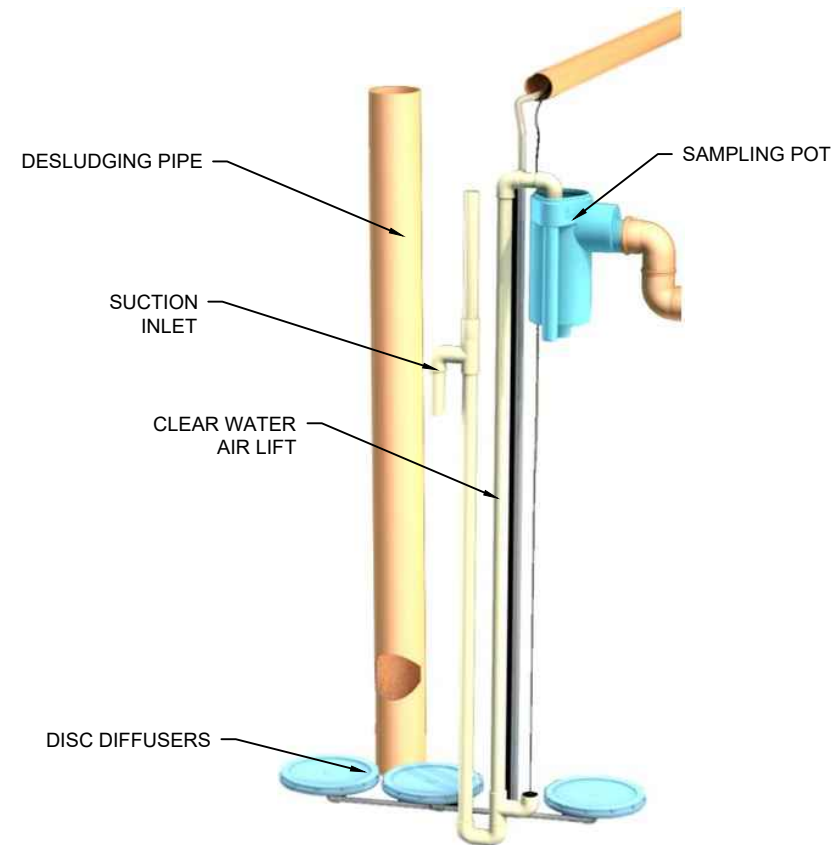

THIS DOCUMENT IS SUPPLIED IN STRICT CONFIDENCE AND MUST NOT BE LENT, REPRODUCED OR DISCLOSED TO ANY THIRD PARTY WITHOUT THE WRITTEN CONSENT OF GRAF UK LIMITED

DO NOT SCALE - IF IN DOUBT ASK

Notice: This drawing is issued only as a guideline and is an estimate of the materials required to construct the drainage system, it should not be used for construction purposes.

Graf UK Ltd makes no warranty or guarantee in relation to the suitability of any of the layout details shown on this drawing in relation to a particular scheme.

NOTES:-

- All dimensions in mm, unless otherwise stated.
- All dimensions are nominal and may vary within manufacturing tolerances.
- All site temporary enabling works by others.
- GRAF products to be installed in strict accordance with GRAF recommendations.
- This drawing is intended for guidance only. Confirmation of the suitability for a particular project should be sought from the consulting engineers prior to final design or commencement of any construction works.

GRAF 15PE ONE2CLEAN SPECIFICATION

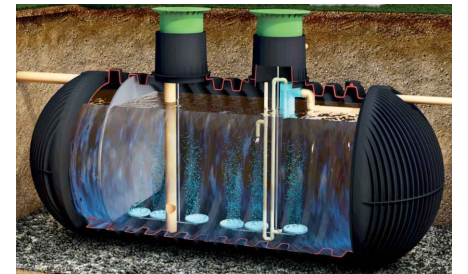

ONE2CLEAN PACKAGE ADD ONS

(SEE PAGE 2 FOR CONTROL PANEL INFORMATION)



CARBON DOSING



PUMPED OUTLET



HYGIENE



DENITRIFICATION



PHOSPHATE REMOVAL



INTERNAL PUMP SYSTEM (IPS)
ONLY SUPPLIED WITH MAXI DOME AND RO



COOLING FAN



WARNING LAMP



DOSING PUMP

Tank Accessories

Item	Diameter ø	Min. Height (mm)	Max. Height (mm)	Max. Loading (kg)*
Pedestrian Loading Lid (Mini)	ø 600mm	60mm	340mm	150kg
Pedestrian Loading Lid (Maxi)	ø 600mm	60mm	440mm	150kg
Vehicle Loading Lid	ø 625mm	60mm	440mm	3,500kg
Extension Sleeve (1m)	ø 670mm	500mm	1,000mm	
Extension Sleeve	ø 680mm	250mm		
Tank Dome (Maxi)	ø 650mm	610mm		
Tank Dome (Mini)	ø 650mm	285mm		
Tank Dome (Micro)	ø 650mm	90mm		

* Loading up to 12,000kg achievable (suitable cover to be provided by others)
** Tank Dome (Maxi) available with DN100 or DN150 connections

Supply Information:

- Pedestrian Loading lid (Mini) is part of the standard supply, all other lids are supplied upon request or unless otherwise specified.
- Tank Dome (Mini) is part of the standard supply, all other domes are supplied upon request or unless otherwise specified.
- If opting for an Internal Pump System (IPS), the system must be supplied with a Tank Dome (Maxi) and a Raised Outlet (RO).
- Raised Outlet (RO) upgrade available upon request, please contact GRAF UK for more information.
- If opting for an Extension sleeve (1m), the sleeve can be cut into smaller sizes of 750mm or 500mm of working height.

P0	LATEST REVISION	KS	21.11.23
REV.	DESCRIPTION	BY	DATE



GRAF UK Limited, Regen House, Beaumont Road, Banbury, Oxfordshire, OX16 1RH

T: 01608 661500

F: 01295 211333

E: info@grafuk.co.uk

www.grafuk.co.uk

DRAWN :	KS	DATE :	21.11.2023
CHECKED :	FC	SCALE :	VARIOUS@A3

PROJECT	GRAF STANDARD DETAILS
---------	-----------------------

DESCRIPTION	GRAF 15PE ONE2CLEAN 10,000L CARAT XL
-------------	---

DRAWING No.	15PE ONE2CLEAN STANDARD DETAIL	REV.	P0
			Page.1

Pedestrian Loading Lid (Mini)
Supplied as standard

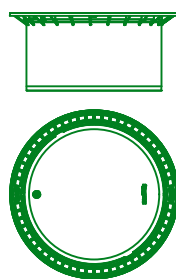

Pedestrian Loading Lid (Maxi)

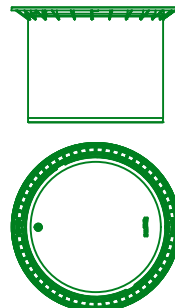

Vehicle Loading Lid

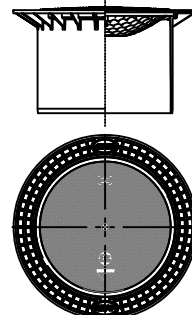

Extension Sleeve (1m)

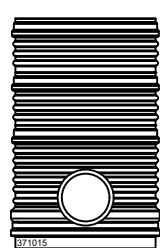

Extension Sleeve

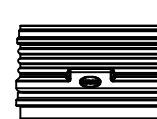

Tank Dome (Maxi)

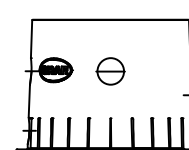

Tank Dome (Mini)
Supplied as standard

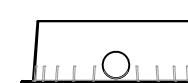

NOTE:- Tank accessory suitability may vary depending on project. Please contact Graf UK for sizing and support.

15PE ONE2CLEAN WITH INTERNAL CABINET

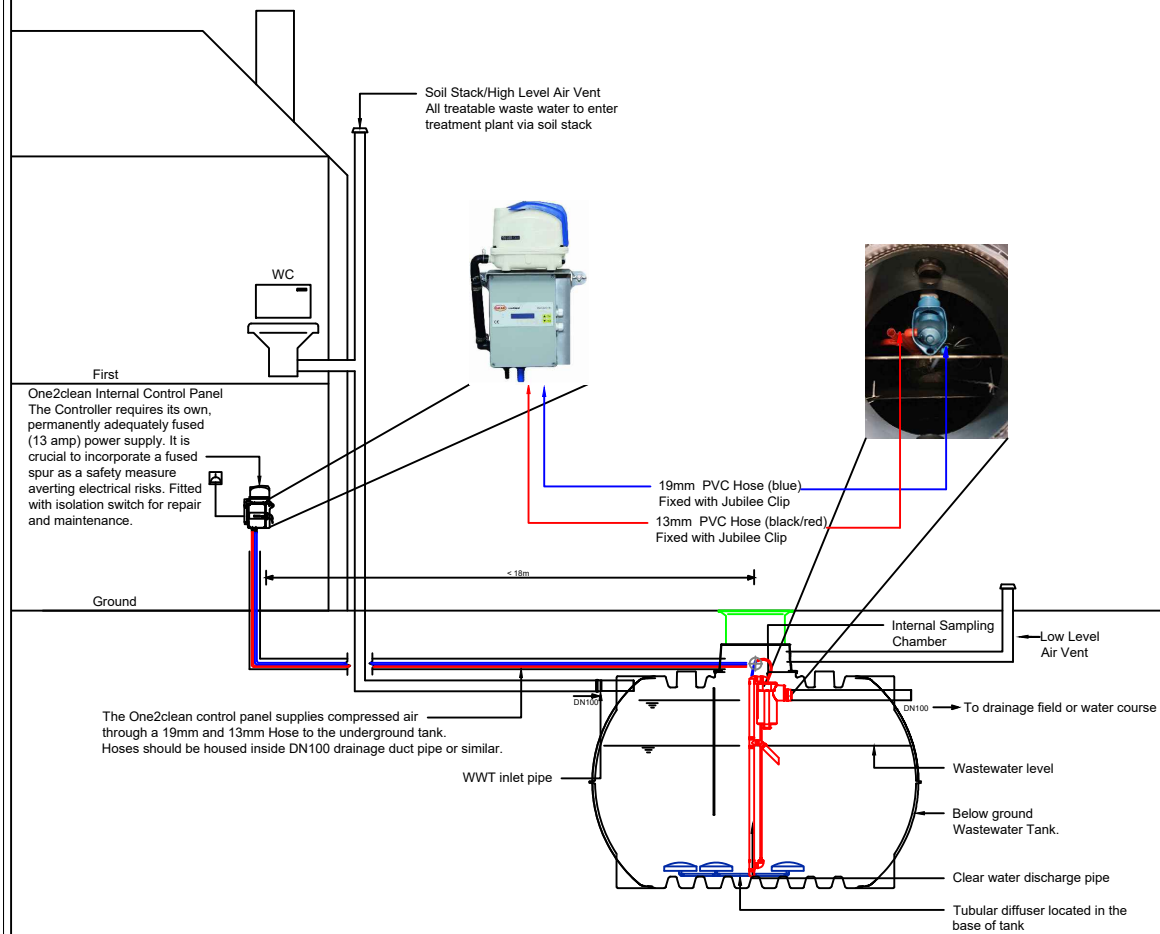

15PE ONE2CLEAN WITH EXTERNAL CABINET

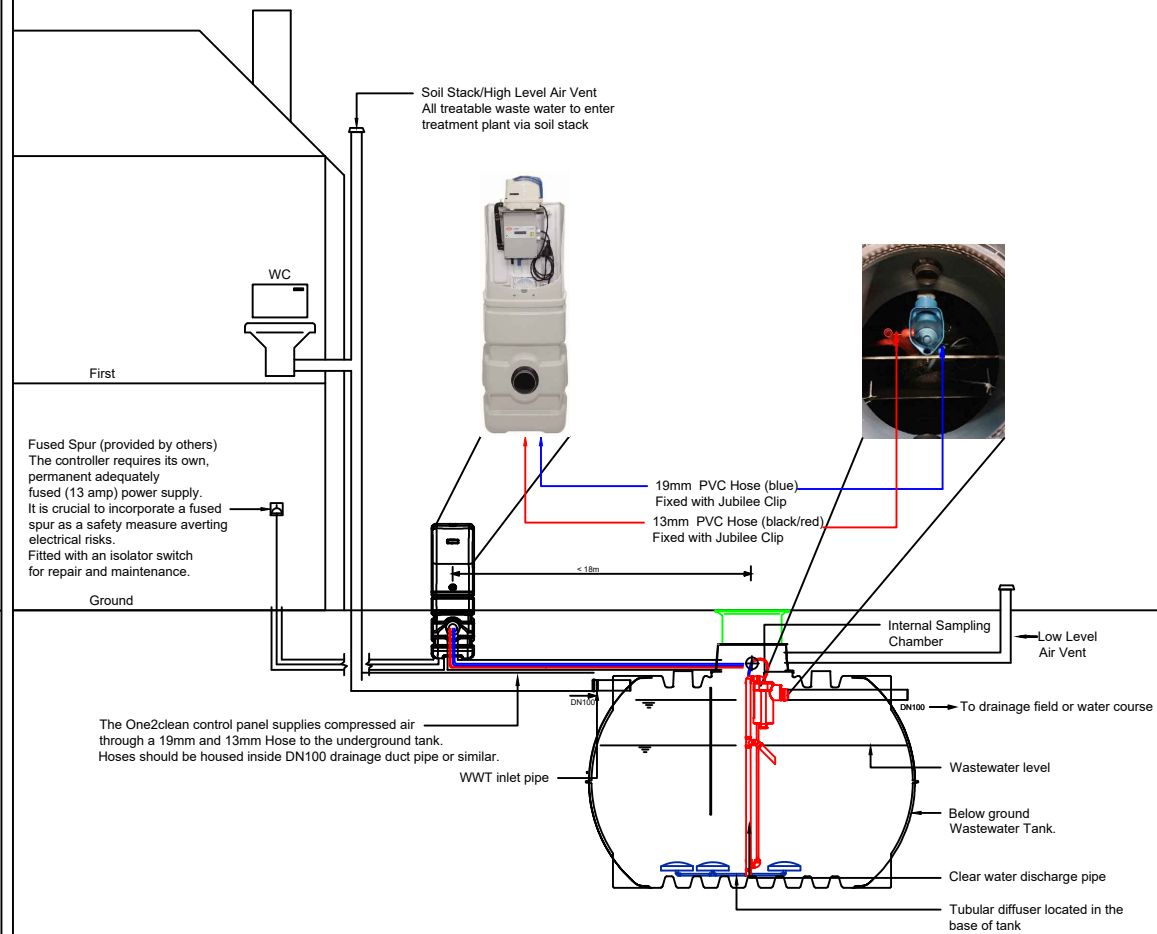

THIS DOCUMENT IS SUPPLIED IN STRICT CONFIDENCE AND MUST NOT BE LENT, REPRODUCED OR DISCLOSED TO ANY THIRD PARTY WITHOUT THE WRITTEN CONSENT OF GRAF UK LIMITED

DO NOT SCALE - IF IN DOUBT ASK

Notice: This drawing is issued only as a guideline and is an estimate of the materials required to construct the drainage system, it should not be used for construction purposes.

Graf UK Ltd makes no warranty or guarantee in relation to the suitability of any of the layout details shown on this drawing in relation to a particular scheme.

NOTES:-

1. All dimensions in mm, unless otherwise stated.
2. All dimensions are nominal and may vary within manufacturing tolerances.
3. All site temporary enabling works by others.
4. GRAF products to be installed in strict accordance with GRAF recommendations.
5. This drawing is intended for guidance only. Confirmation of the suitability for a particular project should be sought from the consulting engineers prior to final design or commencement of any construction works.

GRAF 15PE ONE2CLEAN SPECIFICATION

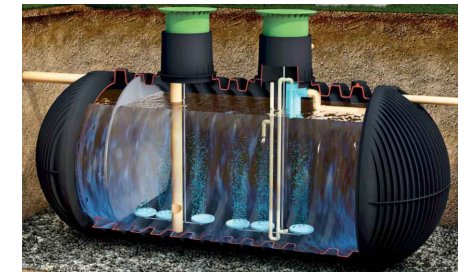

CABINETS

EXTERNAL PLASTIC CABINET S FOR STANDARD ONE2CLEAN CONTROL PANEL



EXTERNAL PLASTIC CABINET M FOR KL CONTROL M PANEL & STANDARD ONE2CLEAN CONTROL PANEL



COMPRESSOR

HIBLOW HP 200 COMPRESSOR



CONTROL PANEL

ONE2CLEAN CONTROL PANEL



SYSTEM HOSES

**PLEASE NOTE THAT HOSE COLOURS MAY VARY*



13MM DISCHARGING AIR LIFT



19MM AERATION

NOTE:- Tank accessory suitability may vary depending on project. Please contact Graf UK for sizing and support.

P0	LATEST REVISION	KS	21.11.23
----	-----------------	----	----------

REV.	DESCRIPTION	BY	DATE
------	-------------	----	------



GRAF UK Limited, Regen House, Beaumont Road, Banbury, Oxfordshire, OX16 1RH

T: 01608 661500

F: 01295 211333

E: info@grafuk.co.uk

www.grafuk.co.uk

DRAWN :	KS	DATE :	21.11.2023
CHECKED :	FC	SCALE :	VARIOUS@A3

PROJECT	GRAF STANDARD DETAILS
---------	-----------------------

DESCRIPTION	GRAF 15PE ONE2CLEAN 10,000L CARAT XL
-------------	---

DRAWING No.	15PE ONE2CLEAN STANDARD DETAIL	REV.	P0
			Page.2

TRENCH DETAILS

FOR SUFFICIENT WORKING ROOM, THE BASE AREA OF THE TRENCH MUST EXCEED THE DIMENSIONS OF THE TANK BY 500mm ON ALL SIDES.

MINIMUM DISTANCE FROM SOLID STRUCTURES TO BE 1000mm.

THE TRENCH EMBANKMENT MUST BE DESIGNED SO SLIPPAGE OR COLLAPSE OF THE EMBANKMENT WALL IS NOT TO BE ANTICIPATED.

THE CONSTRUCTION SITE MUST BE HORIZONTAL AND PLANE AND MUST GUARANTEE SUFFICIENT LOAD-BEARING CAPACITY.

THE DEPTH OF THE TRENCH MUST BE DIMENSIONED SO THAT THE MAXIMUM COVER ABOVE THE TANK IS NOT EXCEEDED (SEE BELOW DETAILS).

THE TANK AND ANY OTHER COMPONENTS THAT CARRY WATER MUST BE INSTALLED IN A FROST-FREE AREA. THE FROST-FREE DEPTH IS USUALLY APPROX. 600mm-800mm. EXACT DEPTHS CAN BE OBTAINED FROM THE RESPONSIBLY AUTHORITY.

A 150mm-200mm COMPACTED LAYER OF 8-16mm ROUND GRAIN GRAVEL IS INSTALLED AT THE BASE OF THE EXCAVATION.

MINIMUM & MAXIMUM COVER

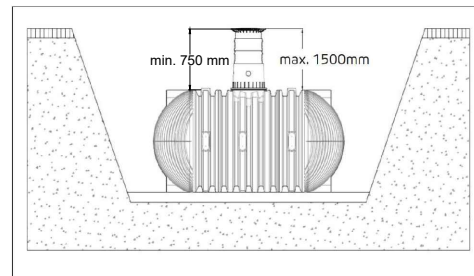

MINIMUM COVER IN A LANDSCAPED AREA TO BE 750mm FROM SHOULDER OF TANK.

MAXIMUM COVER IN A LANDSCAPED AREA TO BE 2000mm FROM SHOULDER OF TANK.

SLOPE/EMBANKMENT INSTALLATIONS

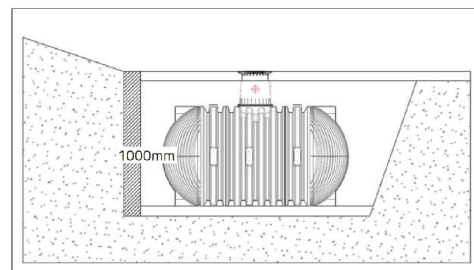

IF THE TANK IS TO BE INSTALLED IN THE IMMEDIATE VICINITY (<5m) OF A SLOPE OR EMBANKMENT, A STATICALLY CALCULATED RETAINING WALL MUST BE ERECTED TO ABSORB ANY ADDITIONAL LOADING FROM THE SOIL. THE WALL MUST EXCEED THE DIMENSIONS OF THE TANK BY AT LEAST 500mm IN ALL DIRECTIONS AND MUST BE LOCATED AT LEAST 1000mm AWAY FROM THE TANK.

GROUNDWATER INSTALLATIONS

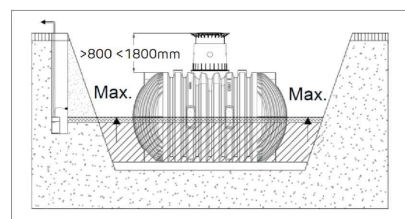

TO MAINTAIN THE DESIRED TANK DEPTH, ENSURE PROPER DRAINAGE IS APPLIED IN AREAS WITH GROUND WATER AND IMPERMEABLE SOIL. USING A DRAINAGE LINE ENDING IN WITH A CHAMBER AND AN IMMERSION PUMP TO PUMP EXCESS WATER AWAY FROM THE SITE. REGULARLY INSPECT THE PUMP FOR OPTIMAL FUNCTIONALITY. IF IT IS EXPECTED THAT THE TANK MAY SINK LOWER, ADEQUATE DRAINAGE MUST BE ENSURED.

TANK SIZE	8,500L	10,000L	13,000L
IMMERSION DEPTH	1042,50mm	1142,50mm	1232,50mm

MINIMUM COVER TO BE 800mm FROM SHOULDER OF TANK IN AREAS WITH GROUNDWATER.

MAXIMUM COVER TO BE 1800mm FROM SHOULDER OF TANK IN AREAS WITH GROUNDWATER.

INSERTION & FILLING

THE TANK MUST BE INSERTED, IMPACT-FREE, INTO THE PREPARED TRENCH USING SUITABLE EQUIPMENT.

THE TANK IS FILLED WITH 25cm WATER BEFORE BACKFILLING. THE 10-20mm ROUND GRAIN GRAVEL IS BACKFILLED IN LAYERS OF MAX. 400mm STEPS AND IS TO BE WELL COMPACTED WITH A MANUAL TAMPER. MECHANICAL COMPACTION MACHINES ARE NOT TO BE USED UNDER ANY CIRCUMSTANCES. SURROUND MUST BE AT LEAST 500mm ON ALL SIDES OF THE TANK.

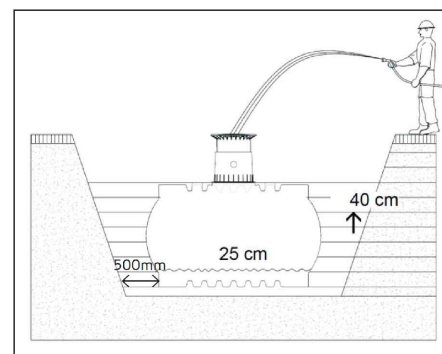

VEHICLE LOADING CONDITIONS

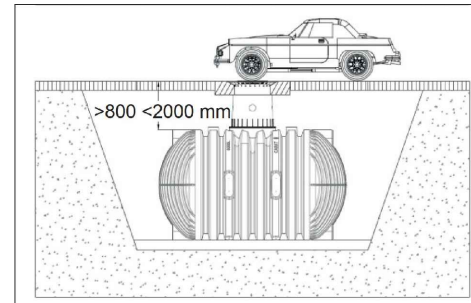

FOR LOADINGS OF UP TO 3,500KG IN TRAFFICKED AREAS WITH NO GROUNDWATER, THERE MUST BE:

MINIMUM COVER OF 800mm FROM THE SHOULDER OF THE TANK, AND

MAXIMUM COVER OF 2000mm FROM THE SHOULDER OF THE TANK.

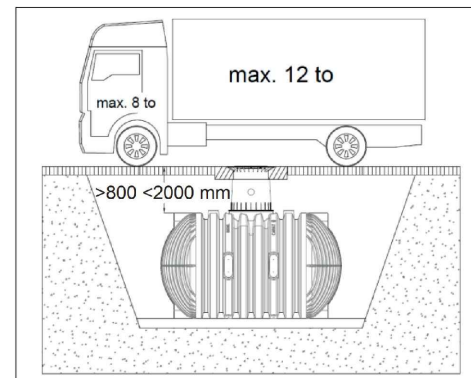

FOR LOADINGS OF MORE THAN 3,500KG AND UP TO 12,000KG IN AREAS OF NO GROUNDWATER, THERE MUST BE:

MINIMUM COVER OF 800mm FROM THE SHOULDER OF THE TANK,

MAXIMUM COVER OF 2000mm FROM THE SHOULDER OF THE TANK, AND

SUITABLE MANHOLE COVER & FRAME (PROVIDED BY OTHERS).

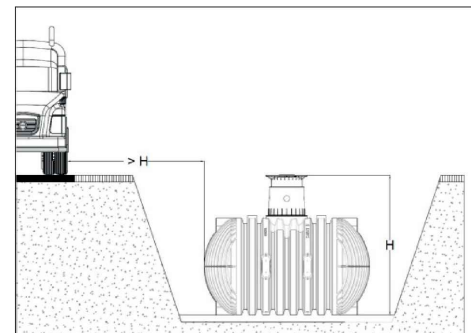

FOR INSTALLATIONS ADJACENT TO SURFACES USED BY VEHICLES OF OVER 3,500KG, THE TANK MUST BE INSTALLED AT A DISTANCE FROM THE ROAD SURFACE THAT IT AT LEAST THE DEPTH OF THE TRENCH.

PIPE CONNECTIONS

ALL PIPE CONNECTIONS MUST BE INSTALLED WITH A FALL OF AT LEAST 1% IN THE DIRECTION OF FLOW (POSSIBLE, SUBSEQUENT SETTLING MUST BE TAKEN INTO ACCOUNT).

IF THE TANK OVERFLOW IS CONNECTED TO A PUBLIC SEWER, THIS MUST BE PROTECTED AGAINST REFLUX BY MEANS OF A LIFTING STATION OR REFLUX SEAL IN ACCORDANCE WITH DIN 1986.

ALL SUCTION, PRESSURE & CONTROL LINES MUST BE INSTALLED IN AN EMPTY PIPE / DUCT AND AS STRAIGHT AS POSSIBLE. ANY NECESSARY BENDS MUST BE FORMED IN 30 DEGREE MOULDED SECTIONS.

IMPORTANT: THE EMPTY PIPE / DUCT MUST BE CONNECTED TO AN APERTURE ABOVE THE MAX. WATER LEVEL.

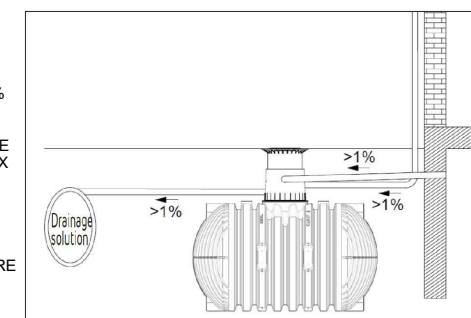

THIS DOCUMENT IS SUPPLIED IN STRICT CONFIDENCE AND MUST NOT BE LENT, REPRODUCED OR DISCLOSED TO ANY THIRD PARTY WITHOUT THE WRITTEN CONSENT OF GRAF UK LIMITED

DO NOT SCALE - IF IN DOUBT ASK

Notice: This drawing is issued only as a guideline and is an estimate of the materials required to construct the drainage system. It should not be used for construction purposes.

Graf UK Ltd makes no warranty or guarantee in relation to the suitability of any of the layout details shown on this drawing in relation to a particular scheme.

NOTES:-

- All dimensions in mm, unless otherwise stated.
- All dimensions are nominal and may vary within manufacturing tolerances.
- All site temporary enabling works by others.
- GRAF products to be installed in strict accordance with GRAF recommendations.
- This drawing is intended for guidance only. Confirmation of the suitability for a particular project should be sought from the consulting engineers prior to final design or commencement of any construction works.

GRAF 15PE ONE2CLEAN INSTALLATION

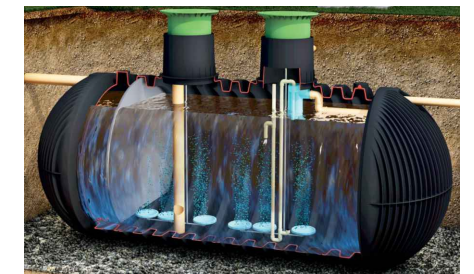

PO LATEST REVISION KS 14.06.23

REV. DESCRIPTION BY DATE

GRAF GRAF UK Limited

GRAF UK Limited, Regen House, Beaumont Road, Banbury, Oxfordshire, OX16 1RH

T: 01608 661500

F: 01295 211333

E: info@grafuk.co.uk

www.grafuk.co.uk

DRAWN : KS DATE : 14.06.2023

CHECKED : FC SCALE : VARIOUS@A3

PROJECT

GRAF STANDARD DETAILS

DESCRIPTION

**GRAF 15PE ONE2CLEAN
10,000L CARAT XL**

DRAWING No. REV.

15PE ONE2CLEAN STANDARD DETAIL

P0

Page.3

PLEASE REFER TO TANK INSTALLATION GUIDE FOR DETAILS ON; SAFETY, PRODUCT FEATURES, IDENTIFICATION OBLIGATIONS, TECHNICAL DATA, TANK STRUCTURE, TANK ASSEMBLY & SERVICING AND INSPECTION.