

ONE PIECE TANK with BVB and AB Air Gap – ANP 5280_2

GENERAL SPECIFICATION INFORMATION

1 Construction

Tank body (not including BVB) shall be of external dimensions 6150x2150x2080mm.

Nominal capacity of 5280 gallons / 24000 litres.

Tank shall be fitted with a raised ball valve chamber of 700x500x300mm incorporating an AB air gap and top access manhole for inlet valve maintenance.

Tank weight approx. 1065.5kg

GRP tank products are manufactured from non-corrosive materials to the requirements of BS EN 13280:2001, incorporating the quality control requirements of ISO 9001:2015, and are WRAS approved. Internal surfaces in contact with the fluid are smooth isophthalic gel-coated with a high gloss finish to improve resistance to bacteriological growth.

Resin is high grade orthophthalic, pigmented, and shall be resistant to ultra-violet attack.

The reinforced glass is to be 'E' glass type and to be long-stranded (40mm minimum). The proportion of glass shall be no less than 30% w/w.

The external finish shall be totally sealed, be sufficiently robust to withstand normal site handling and transportation.

External Colour shall be Beige to BS 4800

All tanks are factory water tested at manufacture stage.

Standard tanks are suitable for storage of water at ambient temperature. Any other proposed applications must be notified and approved in writing.

2 Bracing

Internal ties and fasteners, if fitted, are constructed in high grade stainless steel 316 Grade A4, compliant with EN 1.4401 / EN 1.4436, SAE 316 and UNS S31600.

External reinforcement/fasteners, if incorporated, are mild steel construction to BS 3692 and Galvanised to BS 729, totally encapsulated and protected within the laminate.

3 Insulation

The tank shall be insulated on the sides and roof as standard. The insulation material shall be of rigid closed cell polyurethane foam, have a protective GRP skin integrally moulded to the tank surface. All pipe cut outs shall be integrally moulded and sealed to both the outer skin and internal tank face. All insulation to be a minimum of 50mm thick.

The completed laminate shall equate to a minimum thermal conductance of 0.36 w/m²k respectively.

Insulation products used in our insulation have an Ozone Depletion Potential (ODP) of zero and a Global Warming Potential (GWP) of less than 5.

4 Access

All tanks shall have a flat, Byelaw 30 Cover, suitably supported.

Access to the ball valves shall be via an inspection hatch of minimum 400mm if the size of the cover allows.

It is good practice to provide a minimum 500mm clearance all around the tank to assist pipework installation. A minimum of 750mm is generally required above the tank for future tank and float valve-maintenance.

ONE PIECE TANK with BVB and AB Air Gap – ANP 5280_2

GENERAL SPECIFICATION INFORMATION

5 Connections

Connections if supplied to be site installed & as per tank specification.

All flanged connections <54mm shall be supplied male (BSP) threaded, and all connections >67mm shall be flanged to PN16 (BS5159 & BS4504) unless otherwise agreed.

All pipework, valves etc connected to the tank must be supported independently to reduce stress on the GRP structure.

Overflow and Vent connections shall be supplied with Screens with 0.65mm mesh in line with requirements of BS 13280:2001 to protect against the ingress of insects and particles & should be fitted to maintain required air gaps.

If supplied Type AB air gaps in compliance with BS EN 13077:2008 can be provided. To prevent any risk of light ingress a cowl will be fitted over the AB air gap slot, the cowl will be fitted with 0.65mm nylon mesh in line with requirements of BS 13280:2001 to protect against the ingress of insects and particles.

6 Foundation

Building Regulations Part G

3.15 The cold water storage tank should be supported on a flat, level, rigid platform which is capable of safely withstanding the weight of the tank when filled with water to the rim and fully supporting the bottom of the tank over the whole of its area.

The platform should extend a minimum of 150mm in all directions beyond the edge of the maximum dimensions of the tank.

BS EN 13280:2001

The top surface of the foundation, whether it is flat screed concrete, steelwork, support walls or pillars, should be flat, level and free from any local irregularities. It should not vary more than 2mm in any 1m, or a total of 6mm in any 6m, measured laterally or diagonally. If foundations are to be provided by suspended floors or beams, then the foundation should be constructed so that when the tank is full, the combined deflections should not exceed 1/500th of the span.

Offloading

GRP tanks should be unloaded and moved by fibre slings under the unit and lifting from above from a single point using a suitable crane or lifting equipment.

Dependent on the size of the tank the slings should be positioned approximately 500mm in from each end.

The unit should be slightly raised from its position and it should be assessed whether or not the unit is sufficiently stable to move safely.

If unit is more than 3 metres long, two pairs of slings or a spreader plate should be used to spread the load and reduce stress on the structure.

Do not attempt to move a tank containing any water.

Do not use chains to lift the unit except where they are above the lid and will not come in contact with the tank in any way.

Whilst in temporary storage on site, tanks should be placed on a level surface and care should be taken to ensure that no sharp protruding objects are present that might damage the base.

ONE PIECE TANK with BVB and AB Air Gap – ANP 5280_2

GENERAL SPECIFICATION INFORMATION

Operation and Maintenance

The main lid forms part of the structure and should not be removed unless the tank is empty.

As GRP tank products are manufactured from non-corrosive materials, they require little or no specific maintenance other than good housekeeping.

Annual Inspection – It is recommended that water storage tanks should have an annual inspection to:

- Inspect the effectiveness and operation of the incoming float-valve and/or isolation valve arrangement.
- Inspect the cleanliness of the tank and wash out if necessary, by means of opening the drain valve. Additional washing down with a hose may be necessary.
- Inspect the tank externally for any signs of dampness around its base which may be the result of leaking tank connections, condensation, damage or overflowing. Rectify as necessary.
- Inspect the tank fittings to ensure that any air vents, overflows, warning pipes and filter screens are clean and unobstructed, manways and inspection hatches are secure and sealed, and any access ladders are securely fixed.
- For most installations a test of water quality should be carried out by a competent environmental hygiene technician every 12 months. If test results are unacceptable, the tank should be chlorinated to improve water quality. (Note: Where water quality is unacceptable consideration needs to be given to upstream or downstream sources of contamination).

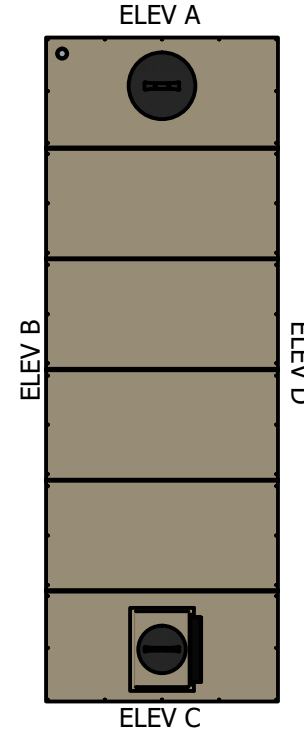
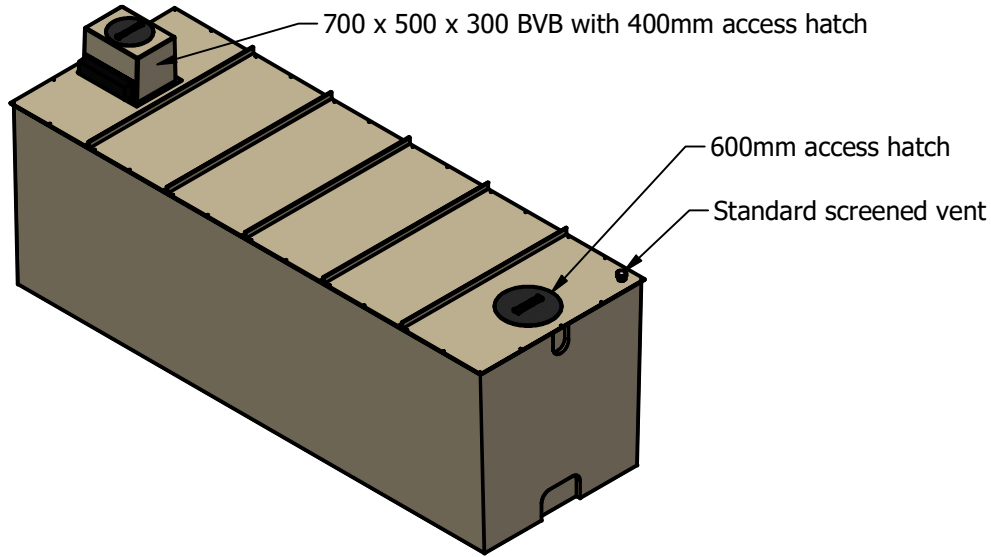

PLAN

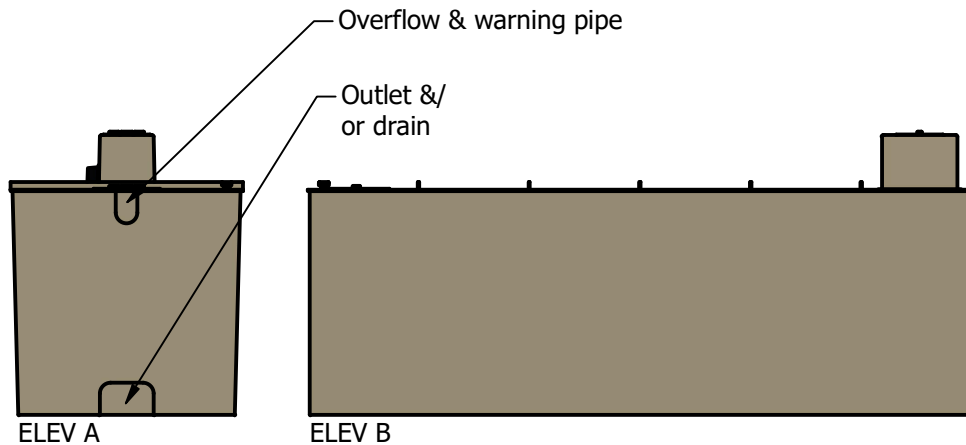
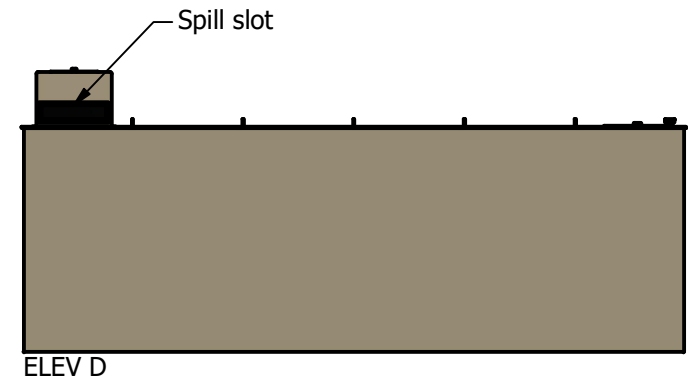
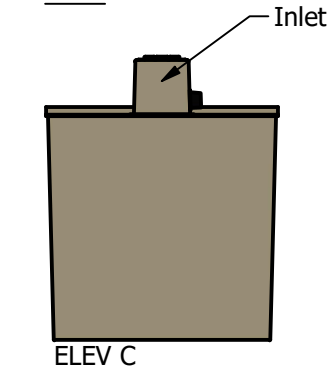

- All dimensions are approximate and may change without notice. If dimensions are required for a specific purpose these can be provided on request.
- Recesses for connections are shown in model.
- Holing of tank and fitting of connections are done by others unless ordered.
- Tank sides may have a small draw angle for moulding purposes.

Created by	Date	Checked by	Date	Issued	A4	SCALE
JM	08-12-22		08-12-22	08-12-22		NTS
NOTE: All Dimensions are in mm				ANP 5280 /2 with 700 x 500 x 300 BVB + 1 spill slot		
External Dimensions: 6150 x 2150 x 2080				Revision	Sheet	
				R000	1 / 1	